

Crank shaft sensor

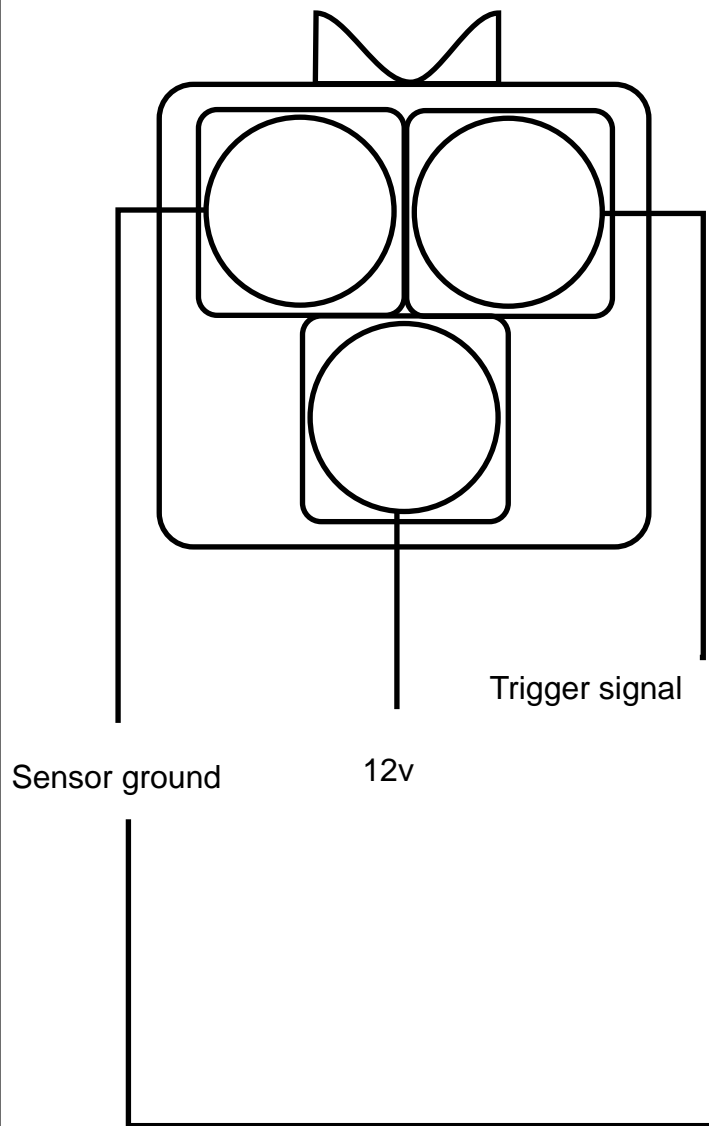

Trigger signal

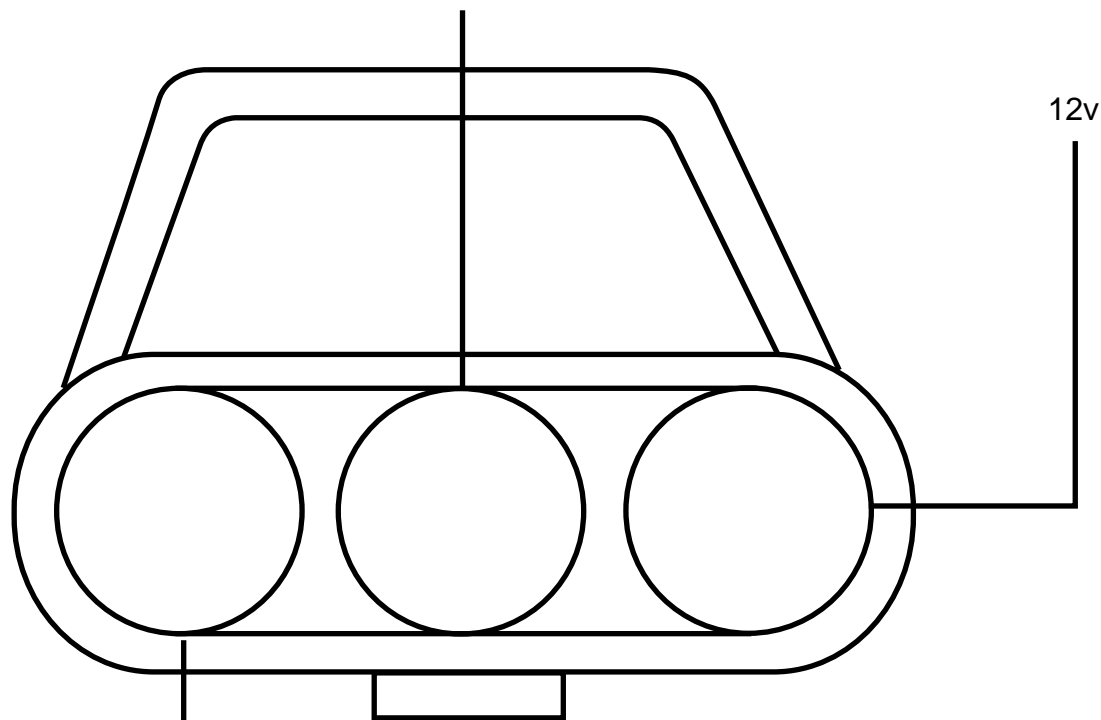

Camshaft sensor

Mitsubishi 4G63 Crank/Cam triggers			WOLF V500
Date 10/05/08	Rev 001	Page 1 of 1	

NOTE:

ECU

IGN GND

31

BL/SHIELD

IGN1

32

R

Tacho 

Mazda RX7 S4

Date: 25/11/02

Rev 001

Page 2 of 3

WOLF3D

Engine Temp Sensor Calibration Table

0.00	0.15	0.31	0.46	0.62	0.78	0.93	1.09	1.25	1.40	1.56	1.71	1.87	2.03	2.18	2.34	2.50	2.65	2.81	2.96	3.12	3.28	2.43	3.59	3.75	3.90	4.06	4.21	4.37	4.53	4.68	4.84
0.00	0.00	0.00	0.00	0.00	0.00	0.00	0.00	0.00	0.00	0.00	0.00	0.00	0.00	0.00	0.00	0.00	0.00	0.00	0.00	0.00	0.00	0.00	0.00	0.00	0.00	0.00	0.00	0.00	0.00	0.00	0.00

Air Temp Sensor Calibration Table

0.00	0.15	0.31	0.46	0.62	0.78	0.93	1.09	1.25	1.40	1.56	1.71	1.87	2.03	2.18	2.34	2.50	2.65	2.81	2.96	3.12	3.28	2.43	3.59	3.75	3.90	4.06	4.21	4.37	4.53	4.68	4.84
0.00	0.00	0.00	0.00	0.00	0.00	0.00	0.00	0.00	0.00	0.00	0.00	0.00	0.00	0.00	0.00	0.00	0.00	0.00	0.00	0.00	0.00	0.00	0.00	0.00	0.00	0.00	0.00	0.00	0.00	0.00	0.00

WMF Files:

The following files can be used as a beginning point to get your engine up and running. Your engine **MUST** be tuned once you have loaded in the file that best represents your engine.

.wmf - description of engine
 .wmf - description of engine

NOTE:

If your engine

Mazda RX7 S4

Date: 25/11/02

Rev 001

Page 3 of 3

WOLF3D